

# Bell & Gossett Model EASB-JR Enhanced Air Separator

## Description

Bell & Gossett's Model EASB-JR Enhanced Air Separator automatically removes entrained air bubbles in hydronic systems. As fluid enters the EASB-JR, the velocity is decreased creating a low pressure area. The small bubbles are released from fluid and then collected on the coalescing medium. As the bubbles coalesce, they rise to the top of the air separator where they are released to atmosphere through the built-in automatic air vent. The air separator has a bottom 1/2" NPT connection to accommodate a B&G diaphragm expansion tank. The compact design and brass body construction make the EASB-JR ideal for residential and commercial hydronic heating systems.

## Operating Data

Maximum working pressure . . . . . 150 psi (10 bar)  
 Maximum operating temperature . . . . . 250°F (121°C)

## Operating Data

Body & Cap . . . . . Brass  
 Coalescing Medium . . . . . Stainless Steel  
 Venting Mechanism . . . . . Non-Ferrous



## Dimensions & Weights

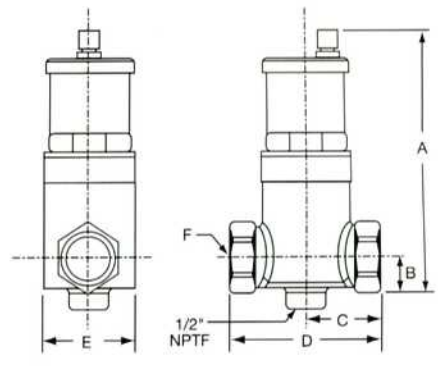

Model Number	Part Number	Size	Dimension in Inches (mm)						Approx. Shpg. Wt. Lbs. (Kg)
			A	B	C	D	E	F	
EASB-3/4 JR	112111	3/4" NPT	6 7/8 (175)	1 5/8 (41)	1 13/16 (46)	3 5/8 (92)	2 1/4 (57)	3/4" NPTF	2.5 (1)
EASB-3/4S JR	112114	3/4" Sweat	6 7/8 (175)	1 5/8 (41)	1 13/16 (46)	3 5/8 (92)	2 1/4 (57)	3/4" Sweat	2.5 (1)
EASB-1 JR	112112	1" NPT	6 7/8 (175)	1 5/8 (41)	1 13/16 (46)	3 5/8 (92)	2 1/4 (57)	1" NPTF	2.5 (1)
EASB-1S JR	112115	1" Sweat	6 7/8 (175)	1 5/8 (41)	1 13/16 (46)	3 5/8 (92)	2 1/4 (57)	1" Sweat	2.5 (1)
EASB-1 1/4 JR	112113	1 1/4" NPT	7 1/2 (191)	1 7/8 (48)	2 5/16 (59)	4 5/8 (117)	3 1/8 (79)	1 1/4" NPTF	4 (1.8)
EASB-1 1/4S JR	112116	1 1/4" Sweat	7 1/2 (191)	1 7/8 (48)	2 5/16 (59)	4 5/8 (117)	3 1/8 (79)	1 1/4" Sweat	4 (1.8)
EASB-1 1/2 JR	112117	1 1/2" NPT	7 1/2 (191)	1 7/8 (48)	2 5/16 (59)	4 5/8 (117)	3 1/8 (79)	1 1/2" NPTF	4 (1.8)

Dimensions are approximate and subject to change. Contact factory for certified dimensions.

# Enhanced Air Separator

## Description

Bell & Gossett's Model EAS Enhanced Air Separator is a patented, innovative design in air separators. It has been engineered to remove entrained air from hydronic heating and cooling systems providing far superior air removal compared with other devices available today. The EAS is ideal for residential, institutional and light commercial applications.

## Operating Data

Maximum working pressure . . . . . 150 psi (10.3 bar)  
 Maximum operating temperature . . . . . 250°F (121°C)

## Operating Data

Body & Cap . . . . . Cast Iron  
 Internals . . . . . Stainless Steel  
 3/4" Large Capacity Air Vent . . . . . Brass Body  
 Nonferrous Internals

## Dimensions & Weights

Model No.	Part No.	Max. Flow (GPM)	Size Inches NPT	Dimensions — Inches (mm)					Approx. Shpg. Wt. lbs. (Kg)
				A	B	C	D	E	
EAS-1	112105	35	1	12-3/16 (310)	6-7/8 (175)	6-7/16 (164)	3-15/16 (100)	3 (76)	8.8 (4)
EAS-1-1/4	112106	35	1-1/4	12-3/16 (310)	6-7/8 (175)	6-7/16 (164)	3-15/16 (100)	3 (76)	8.4 (3.8)
EAS-1-1/2	112107	45	1-1/2	15-3/4 (400)	11-3/8 (289)	8-5/8 (219)	4-7/8 (124)	4-1/4 (108)	15.5 (7)
EAS-2	112108	70	2	17-1/2 (445)	11-3/8 (289)	8-5/8 (219)	4-7/8 (124)	4-1/4 (108)	15.25 (6.9)

EAS-1 or EAS- 1-1/4 Max. Width 4-1/16" (103mm)  
 EAS- 1-1/2 or EAS-2 Max. Width 5-3/4" (146mm)

## How It Works

- 1 As system fluid enters through the inlet, (either straight or angle) the diffuser distributes flow evenly across the stainless steel, wire brush-like medium.
- 2 Air bubbles, even micro air bubbles, stick to the brush filaments.
- 3 Trapped air rises above the diffuser through a baffle (not pictured), where the air is then released through an opening on top.
- 4 Deaerated water then goes back into the system.

